

- NEW -
with S and
K output

SIPART DR19 Controllers

3



	Page
Description	3/2
Application, design	3/2
Mode of operation	3/3
Function diagram	3/9
Operating and display functions	3/10
Configuring switches, on-line-/off-line parameters	3/13
Technical data	3/14
Ordering data	3/17

SIPART DR19 Controllers

Description



Fig. 3/1 SIPART DR19 controller

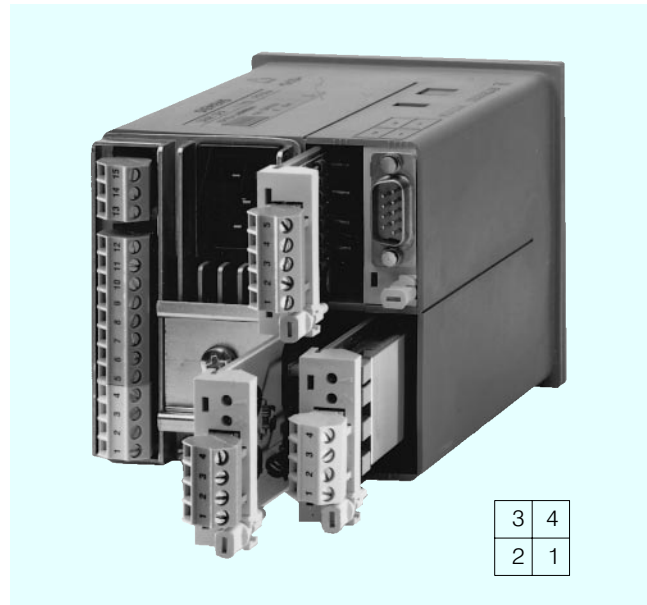

Fig. 3/2 SIPART DR19 controller - rear view, slots

3

Application

The SIPART DR19 process controller is a digital controller. It is mainly used for applications in mechanical engineering and device manufacture. Its internal program memory contains a large number of standard functions for the control of process engineering applications. A user with no programming knowledge can simply call up and execute these functions.

It includes as standard an input for direct connection of temperature sensors such as thermocouples (TC), Pt 100 resistance thermometers (RTD), resistance based sensors (R) or voltage signals in the mV range (also mA and V with adaptor plug).

The SIPART DR19 controller is very flexible and can be quickly and easily configured to meet the requirements of the application.

An adaptation process is built in as standard.

The SIPART DR19 controller can be used as a:

- Fixed setpoint controller with 2 internal setpoints, optionally for one, two or three-component control
- Fixed setpoint controller with up to 5 internal setpoints, optionally for one, two or three-component control
- Slave, synchro or SPC controller, with the option of internal/external switchover
- Fixed or controlled ratio controller with internal/external switchover
- M/A control station, process variable indicator or setpoint transmitter. The control algorithm is disabled in these cases
- Program controller/transmitter, optionally for one, two or three-component control.

Design

The SIPART DR19 controller is of modular design and consequently easy to service and simple to reconfigure or retrofit. The standard unit is fully functional. Additional modules (signal converters) can be inserted into the slots at the rear of the closed unit in order to extend its range of applications (Fig. 3/2).

Slot assignments:

- slot 1 analog input 3 (AE3)
- slot 2 analog input 2 (AE2)
- slot 3 digital inputs/outputs (BE/BA)
- slot 4 interface modules

The standard unit comprises

- Front module (controls and displays with motherboard and CPU)
- Backplane
- Plastic moulded housing with fittings for installation in control panels, consoles or machines.

The backplane contains the power supply unit and connectors. It is installed in the rear of the housing and is connected to the front module by a ribbon cable.

Description

The standard unit has a fixed analog input and two digital inputs. The analog input is designed for the connection of the following sensors:

- Pt 100 resistance thermometer with 2, 3 or 4-wire circuit.
- Thermocouples with internal reference junction (reference junction terminal 6DR2805-8A required) or with external reference junction.
- mV signals
- Resistance based sensors (potentiometers) with 2 wire circuit.
- 10 V and 20 mA signals via additional measuring range plug (6DR2805-8J).

The sensor and the measuring range are determined in the configuring levels StrS (configuring switches) and CAE1 (calibrate analog input 1).

The following are available for the output of the manipulated variable and the state signals:

- Analog output 0/4 to 20 mA
- 2 relay outputs
- 2 digital outputs.

The inputs and outputs can be extended by input/output modules.

Input/output modules are available for:

- current or voltage input (U/I)
- UNI module for TC/RTD/R/mV, also mA and V with adaptor
- Resistance input (potentiometer) (R)
- Digital inputs and outputs (BE/BA)
- Relay outputs (Rel)
- Serial interface (SES)
- PROFIBUS-DP module

Electrical supply for the transmitters is provided by a short-circuit-proof $L+$ output.

The tagging label is replaceable.

Available versions

- 6DR1900-4 for 24 V AC/DC auxiliary supply
- 6DR1900-5 for 230 V AC auxiliary supply, switchable to 115 V AC.

Mode of operation

The SIPART DR19 controller is based on a modern, highly integrated microcontroller using C-MOS technology.

The instrument's internal program memory contains a large number of functions for the control of process engineering applications.

Configuring - the setting of parameters and configuring switches - enables the users themselves to select the functions required for their applications.

The instrument can be configured either from the front panel or via a PC using the SIPROM DR19 or SIMATIC PDM software package.

On leaving the factory, the SIPART DR19 controller is configured as a fixed setpoint controller. In most cases only a few additional settings therefore need to be made.

The instrument parameters are stored in non-volatile memory, and are consequently safe from the effects of a power failure. A backup battery is not required.

The SIPART DR19 controller can be operated as a P, PD, PI or PID controller.

Adaptation process

The adaptation process in the SIPART DR19 controller is easy to use and features short optimization times. Adaptation can be carried out in manual or automatic mode (closed loop). For temperature controllers with two-step outputs for heating and cooling, the splitting of the y control range is carried out automatically. This provides optimization of the parameters for the heating range and the cooling range.

Analog input

The SIPART DR19 controller has a total of 3 analog inputs that can be allocated to the "function inputs" x_1 , x_2 , x_3/we , y_N , y_R and z .

One analog input is provided in the basic unit, 2 further inputs can be added as options.

The function inputs act as the analog input channels for the different types of controller. The role of the function inputs therefore depends on the configuration of the controller.

Function input z is used as an input for the feedforward control, where the disturbance z can either be connected dynamically via the D element or statically, weighted by a factor, to the manipulated variable y .

A 1st order filter for the suppression of external interference and a square root extractor can be connected in each analog input channel.

A linearizer with 13 vertices and knee-point smoothing can be connected to one of the analog inputs.

Description

Program controller/transmitter

(configuring switch S1 = 5).

In this function, a programmer (time scheduler) is connected as a process variable to the controller module.

The programmer has the following features:

- A total of 15 program steps (intervals) that can be used as one program or divided into two programs P1 and P2 (10 and 5 steps)
- In all the intervals, the interval time and the target setpoint can be set at the end of the interval
- The interval times can be set in min/sec or hrs/min
- The following commands can be issued via the front panel or via digital signals:
 - start program
 - stop program
 - reset program sequence
- 6 digital outputs (time bars) for status indication of intervals 1 to 15
- Selectable start conditions following power failure, including start from last value before power failure.

For use as a program transmitter, the time-dependent setpoint can be output directly through the analog output.

Controller manipulated variables

■ K controller (continuous output)

In this configuration of controller, the manipulated variable is output as a standardized current signal. The signal range (0/4 to 20 mA) is determined when the controller is configured.

■ S controller (switching output)

It is preferably to use the floating relay contacts to output the manipulated variable. These contacts are provided with a protection circuit adapted to the contactor coils.

It is important to ensure that the maximum switching voltage is not exceeded. Phase shifting motors must therefore only be connected via intermediate switching devices.

The relay contacts are mutually interlocked. This interlock can be disabled for a universal digital output.

Digital outputs are at disposition to output the manipulated variable at a high switching rate.

Used as S controller, the analog output can then be used for output of an internal process quantity (x , w or x_d).

■ Two-step controller

The manipulated variable y is output as a pulse duty factor with a variable period. In the case of two-step controllers with heating/cooling outputs, a different period can be allocated to each output. Each stage then runs through the pulse duty factor from 0 to 100 %. The dead zone between the heating/cooling stages can be entered as a parameter.

Main application for this type of controller: temperature controller that, for example, switches the heating or cooling power on and off, or that opens and closes a solenoid valve.

Digital input and output

The 2 digital inputs and outputs in the standard controller are connected during configuring to the digital functions required for the application.

They are non-isolated and operate in either normal or inverted mode, depending on how the controller is configured.

The digital outputs are active. They provide a DC voltage signal.

The number of digital inputs and outputs can be increased by installing additional option modules.

In addition, a coupling relay module can be snapped onto the DIN rail on the rear of the controller. This module can have either 2 or 4 relays, each with 1 changeover contact for 250 V AC, 8 A, which are controlled from the digital outputs.

■ Digital inputs

CB	Computer ready
He	Manual mode, external
N	Tracking
Si	Safety mode
P	Controller P mode
tS	Disable setpoint ramp time or reset program sequence
±yBL	Direction-dependent blocking of manipulated variable
BLB	Blocking of command level
BLS	Blocking of configuring
BLPS	Blocking of parameterisation and configuring
PU	Program switchover with program controller or setpoint selection with fixed setpoint controller with 4 (5) setpoints (in conjunction with CB)

■ Digital outputs

RB	Computer ready
RC	Computer mode
H	Manual mode
N_w	Setpoint tracking mode
A1,2,3,4	Alarm monitors A1, A2, A3, A4
MUF	Transmitter fault
±Δw	Incremental w adjustment (S1 = 4)

Description

Display technology

The SIPART DR19 controller is equipped with easy to read displays.

There are digital indicators for both the actual value x (red) and the setpoint w (green, switchable between w and y), an analog indicator that can be configured for internal process values in the controller, and signal and status indicators.

The two four-figure digital LED indicators are arranged one above the other to allow direct setpoint/actual value comparison, and can be configured to show physical units or percentage values.

The analog display is implemented as a vertical LED bargraph. For indication of operating status and alarms, 11 LEDs are provided on the front of the unit.

Some of these displays and controls may be assigned different functions in the configuring levels.

Configurable functions

Application-specific circuits are prewired in the EPROM of the SIPART DR19 controller and can be easily called up.

The configurable functions of the controller (configuring switch S1) are shown below as block diagrams and described briefly. For the sake of clarity, only the most important functions are discussed.

The constants c_1 to c_7 shown in the following diagrams can be entered as parameters.

An additional disturbance can be superimposed on the manipulated variable either dynamically via the D element or as a static value through the function input z .

■ Configuring switch S1 = 0, fixed setpoint controller

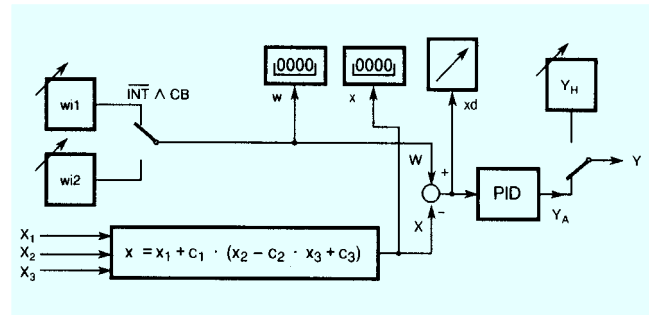

Fig. 3/3 Fixed setpoint controller with one or two independent setpoints as one, two or three-component controller

The setpoints w_{11} and w_{12} can be individually adjusted from the front module. The switchover function can be blocked.

■ Configuring switch S1 = 1, fixed setpoint controller with 5 setpoints

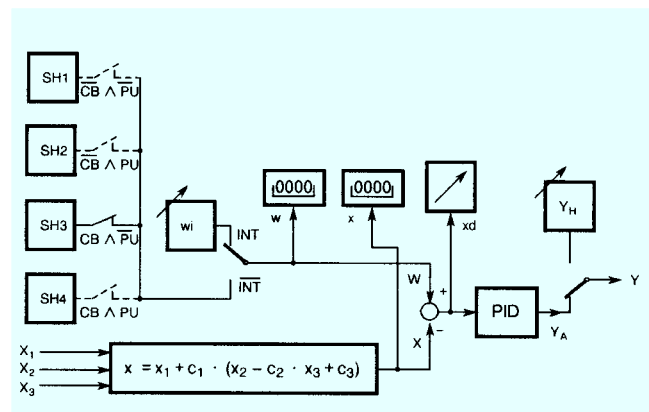

Fig. 3/4 Fixed setpoint controller with 5 independent setpoints as one, two or three-component controller

Setpoint w_1 can be set from the front panel, setpoints SH1 to SH4 are set in the controller parameterization level.

Switching between the various setpoints is achieved by the internal/external button and the control signals CB and PU. The function of the internal/external button can be blocked.

Description

- Configuring switch S1 = 2, slave, synchro or SPC controller

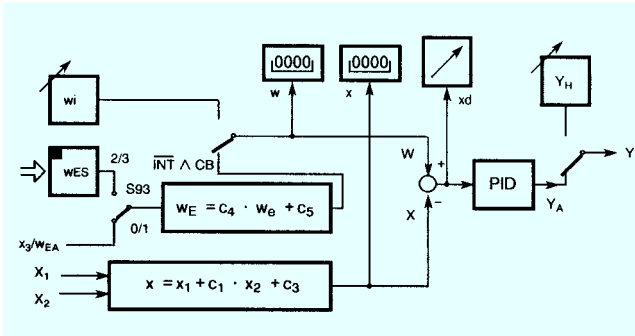

Fig. 3/5 Slave, synchro or SPC controller (Setpoint Control) with internal/external switchover

The remote setpoint can be entered in the controller as an analog signal through the function input x_3 or via the serial interface.

For synchronization purposes, the constant c_3 can be added to the setpoint, which can be also weighted by the factor c_4 .

- Configuring switch S1 = 3, ratio controller

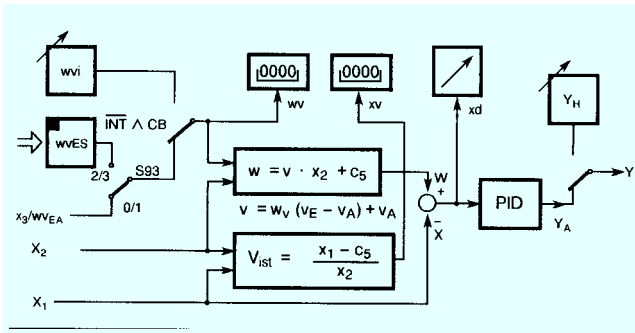

Fig. 3/6 Fixed or controlled ratio controller with internal/external switchover

The controlled variable and weighted command variable are entered in the controller through the function inputs x_2 and x_1 . With this type of controller, the variable setpoint value is not an absolute value, but is specified as a factor v (w_v) derived from the ratio between the controlled variable and the command variable.

The standardized setpoint ratio w_v and actual ratio x_v are displayed in the 4-digit digital indicators, the control difference is displayed in the analog indicator.

The ratio factor can be controlled externally. In this case the switchover structure is the same as that of a slave controller. The instrument operates as a fixed ratio controller if internal/external switchover is blocked.

- Configuring switch S1 = 4, M/A control station/process variable indicator

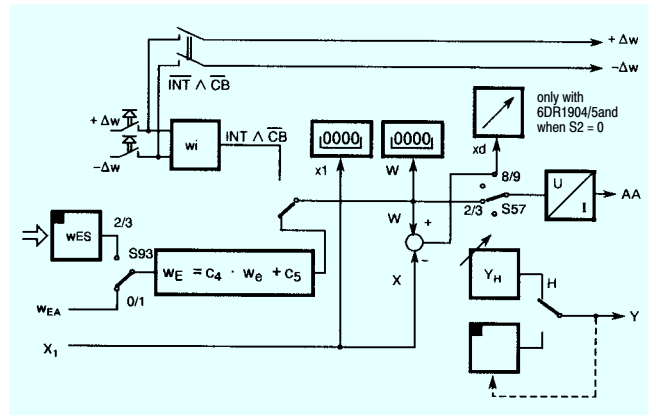

Fig. 3/7 M/A control station/process variable indicator

In this configuration, the SIPART DR19 controller is used as a:

- M/A control station for parallel process operation with a controller
- Manual control unit for the output of an analog or switching setpoint or manipulated variable value
- Process variable indicator for up to 3 measured values
 - Two digital indicators. If the measuring range is the same, the display can also be in physical value
 - An analog indicator 0 to 100 %
 - Monitoring of up to 4 variable limit values
 - Optional switchable display of limit values on the setpoint indicator.

The following output response is possible depending on how the controller is configured (configuring switch S2):

- K or dual setpoint output
- S output with internal feedback
- S output with external feedback.

Description

- Configuring switch S1 = 5, program controller/transmitter

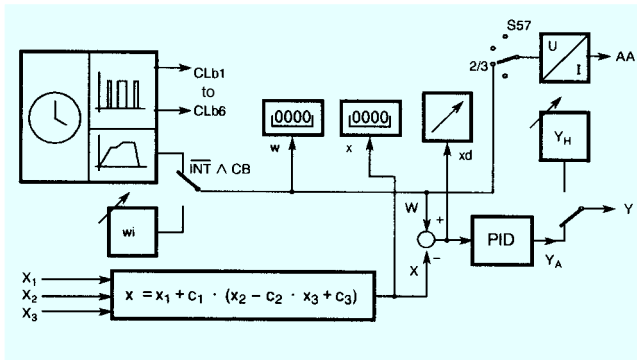

Fig. 3/8 Program controller/program transmitter

The function of the program controller is comparable to the fixed setpoint controller with two internal setpoints. The setpoint w_1 has a fixed value, the time-dependent setpoint is determined by a program.

The start, stop and reset program functions are linked to the controller operation (manual/auto switchover button and internal/external switchover) and to the control signals CB, \bar{tS} and PU.

When used as a program transmitter, the program output values are output via the analog output.

The input configuration is designed for one, two or three-component control.

Other configurable functions to enhance the ease of use and operational safety of the SIPART DR19 controller.

- Transmitter monitoring

A message is output on the 4-digit digital indicator "PV-X" whenever the measurements go out of limits ($< -3\%$ or $> +103\%$ of the signal range). A different message can be output for each input. A group fault message can be output on the MUF digital output.

Furthermore, automatic switchover to manual mode, starting with the value of the last manipulated variable or the safety value, can be selected.

- Setpoint limitation

The effective setpoint value is always limited.

- Setpoint ramp

The t_s parameter specifies the rate of change of the setpoint value. The decimal point in the w display signals the active setpoint ramp (as moving script).

The setpoint ramp can be switched off by the t_s control signal.

- x-tracking

In manual and tracking mode, and also when the safety value is active, the setpoint w tracks the controlled variable x .

- Filter and response threshold of control difference

The control difference is controlled by an adaptive filter (tF) so that low-frequency interference can also be filtered out.

If the output of the controller needs to be stabilized more, a response threshold for the control difference can be entered.

- Varying the direction of control

The default setting of the controller is for normal-action control loops. The direction of action of the controller should be inverted in the case of reverse-action control loops.

- Special features of the control algorithm

The P(D) and PI(D) control algorithm for the controller is implemented as a non-interacting parallel structure and is independent of the output structure (S or K) of the controller.

The switchover from PI(D) to P(D) control is performed by a control signal (binary input). In P(D) mode, the specified K_P value multiplied by the constant c_7 is used.

The switchover from automatic to manual mode (and vice versa), plus the switchover to automatic from all other modes of operation, is bumpless.

This function is also operative in P(D) mode with automatic setting of the working point Y_0 .

If this is undesirable, the working point in P(D) operation can be set manually if required (using parameter Y_0). Switchover to automatic will then not be bumpless. In the case of S controllers, P mode is only permitted with external position feedback.

- Limiting the manipulated variable

The parameters Y_A and Y_E can be used with K output and S output with external feedback to limit the manipulated variable.

Limiting the manipulated variable like this is - depending on how the controller is configured - only possible in automatic mode or in all modes.

In addition to the fixed limiting of the manipulated variable described here, an additional, direction-dependent limiting of the manipulated variable is provided in the SIPART DR19 controller. This limiting is activated by the control signals $+yBL$ and $-yBL$ and is effective in all modes of operation.

Description

■ Limit monitor

The alarm functions A1/A2 and A3/A4 can be assigned in pairs to monitor all internal controller process variables. They can also be configured to monitor maximum-minimum, maximum-maximum or minimum-minimum values.

Violations of minimum/maximum values are indicated on the A1/A2 and A3/A4 LEDs and can be configured to output messages on the digital outputs, the logic of which can be inverted.

The limit values are normally specified in the parameterization level. The alarms may also be specified and displayed in the process operation level (w digital indicator).

The hysteresis for the pairs of limit monitors is specified as a parameter.

■ Restart conditions

Short dips in the mains voltage are, depending on the current loading of the instrument, handled by the buffering capability of the power supply unit.

In the case of a longer power failure, the parameters and configuring data that have been entered are retained in a non-volatile user program memory. The most recent mode of operation and the last setpoint and manipulated variable values are also held in non-volatile memory.

When power is restored following a power failure or after the controller is switched on, the controller automatically restarts using the configured mode of operation, setpoint and manipulated variable values. An optical signal can also be generated to indicate that power has been restored following a power failure.

■ Self-diagnosis

Comprehensive monitoring routines check the internal data traffic cyclically or following a POWER-ON or Watchdog reset.

If an error is detected, an error message is automatically output on the "PV-X" digital indicator. The error message indicates the cause of the error and how it can be remedied.

■ Communication with higher-level systems

The SIPART DR19 controller can transmit and receive status flags, process variables, parameters and configuring switch settings via a serial interface module.

The following interface modules are available:

PROFIBUS DP module

- Transmission rate up to 1.5 Mbits/s
- Up to 125 stations can be a (number of possible stations on the PROFIBUS by the master interface module, the data range of the interface module, and the number of parametrized process data)

SES Module RS 232/RS 485

- Transmission rate 9.6 kbits/s
- RS 232 as point-to-point connection or SIPART bus up to 32 stations
- RS 485 up to 32 stations

The advantages of the stand-alone SIPART DR19 controller can still be utilized to the full, even when used in conjunction with supervisory systems:

- Straightforward adaptation of each controller to meet the requirements of the task in hand
- Operational safety: if the supervisory system, or part of it, shuts down or fails, the SIPART DR19 controller continues to function as an independent controller under the same conditions as before
- Flexibility: modifications or additions to individual control loops are also possible while the system is in use
- Downloading the functions of the controller to individual devices in SPC mode lightens the load on the supervisory system.

Input/output modules (option modules)

The hardware configuration of the standard unit can be extended to cater for special requirements. A range of modules, which can be ordered as accessories, are provided for this purpose.

These modules are inserted in slots in the rear of the controller. The slots are coded to prevent modules being inserted incorrectly.

Some settings on the I/U, R, SES modules may need to be modified before they are inserted in the controller.

Configuring switches are used to make the necessary connections to the inputs and outputs.

The coupling relay modules are snapped onto a DIN rail on the rear of the controller.

Description

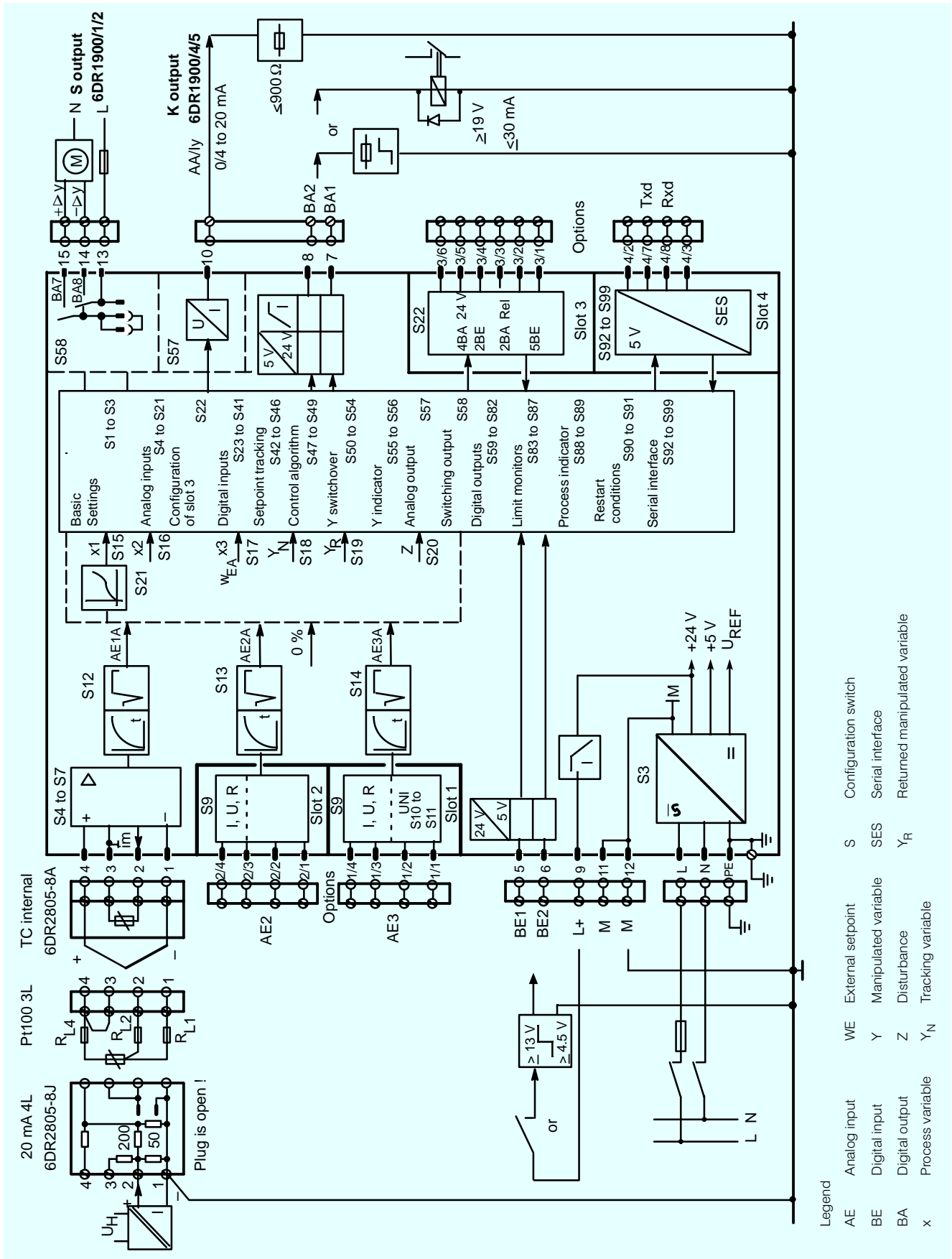

Fig. 3/9 SIPART DR19 controller, function diagram

Description

Controls and display functions

The setting of parameters is distributed over several configuring levels. This makes it very straightforward and simple to modify the controller configuration to the task in hand.

To enter the individual levels, several inputs have to be made explicitly within a specified time limit. Incorrect operation of the controller is therefore practically impossible.

Operation of the SIPART DR19 controller takes place at 3 levels:

- Process operation level
- Selection level
- Configuring level

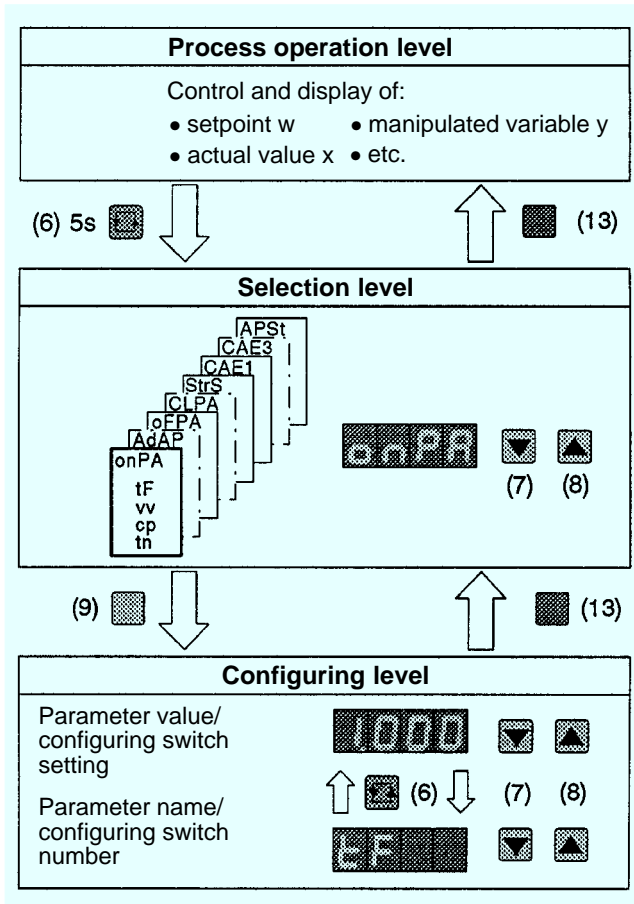

Fig. 3/10 Control levels of SIPART DR21 controller

Process operation level (Fig. 3/11)

The layout and color of controls, displays and the front fascia itself make operation of the SIPART DR19 controller in this mode self-explanatory.

The four-digit red digital indicator (1) shows either the actual value x , the four-digit green indicator shows the setpoint w or the manipulated value y . Optionally, limit values A1 to A4 can also be shown. Pushbutton (6) is used to select the indication.

The LED bar graph (3) can be used to display x_d , x_w or any desired process value.

The internal setpoint value or the manipulated variable y is set using pushbuttons (7) and (8). The controller must be in manual mode to set the manipulated variable.

Switchover to input of setpoint w can also be made in manual mode.

The rate of change of the setpoint and of the manipulated variable in the case of the K controller increases the longer a button is pressed.

Pushbutton (13) is used to toggle between internal and external setpoint. LED (15) illuminates when the internal setpoint is being used. Setpoint switchover is disabled when the controller is shipped from the factory.

The yellow pushbutton (9) toggles between manual and automatic mode. Which mode is active is signalled by the yellow LED (11).

Another yellow LED (10) indicates external modification of the manipulated variable, e. g. in tracking mode.

The output of actuating increments in all modes of the S and two-step controllers is shown in the setpoint and actual value indicators by LEDs (12).

Violation of limit values is indicated by the LEDs (17).

LED (16) signals the progress of parameter optimization during adaptation through either a steady or flashing light.

When operating as a program controller/program transmitter, the following indications, differing from the above are possible.

- Current setpoint w (2). This can be switched over to indication of target setpoint at the end of the interval.
- Current actual value x (1). This can be switched over to remaining time in interval.
- x_d/x_w indication on the LED bargraph (3). This can be switched over to program progress with current program step and end of program.
- Indication of selected program P1 or P2 with LEDs A1/A2 (17).

Description

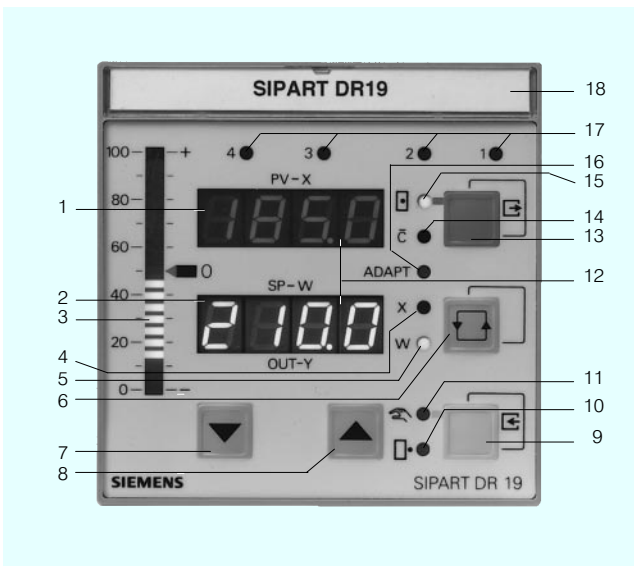

- | | |
|----|---|
| 1 | Digital indicator "PV-X" for actual (process) value x (pv) |
| 2 | Digital indicator "SP-W" for setpoint w (sp) or manipulated value y (out), other values can be displayed |
| 3 | Analog indicator for e (x_d) or -e (x_w), other values can be displayed |
| 4 | Signal lamp "x", illuminates if digital indicator PV-X (1) is active as input field |
| 5 | Signal lamp "w", illuminates if w is being displayed on digital indicator SP-W (2) |
| 6 | Switchover button for digital indicator "SP-W" (2)
Button to acknowledge flashing following restoration of power or entry button for selection level |
| 7 | Button to modify manipulated variable - down (up) or button "setpoint down" |
| 8 | Button to modify manipulated variable - up (down) or button "setpoint up" |
| 9 | Switchover button "manual/auto" or "enter" button to enter configuring level from the selection level |
| 10 | Signal lamp "external y mode" |
| 11 | Signal lamp "manual mode" |
| 12 | Signal lamps of Δy digital outputs with S controller |
| 13 | Switchover button "internal/external setpoint" or "exit" button to exit configuring and selection level and return to the process operation level |
| 14 | Signal lamp "computer (with w_{ext}) switched off" |
| 15 | Signal lamp "internal setpoint" |
| 16 | Signal lamp "adaptation in progress" |
| 17 | Signal lamp "limit value violated" and for setpoint tracking functions L1 to L4 |
| 18 | Tagging label |

Fig. 3/11 Controls and displays

Selection and configuring levels

First of all, the function of the front control and display panel is switched from the process operation level to the selection level.

This is done by pressing and holding the pushbutton (6) until a flashing "PS" is displayed on the "SP-W" digital indicator. On releasing the pushbutton, the display "PS" changes to "onPA". The controller is now in the selection level, from where the parameter lists, the configuring switch list or commissioning functions can be selected.

Use the pushbuttons (7 and 8) to page through the selection level.

Having changed to configuring level, the parameter and configuring switch settings of the selected lists can be displayed and modified.

Controller operation continues during the setting of the "on-line parameters". The response of the control loop to changes in the control parameters can therefore be seen immediately.

The output of the controller is blocked when setting the configuring switches, the off-line parameters or the settings of the UNI module.

- The K controller freezes the last control current.

- The two-step controller freezes the last pulse duty factor.

- The S controller issues no more positioning pulses.

A zebra pattern is displayed in the analog indicator to indicate off-line mode.

The configuring levels

AdAP (adaptation)

CAE3 (calibration "UNI module" on analog input 3) and

CLPA (clock parameters, alternative version of unit)

are only displayed if they have been configured.

Lamp test

If pushbutton (6) is pressed and held for more than 5 sec., all LEDs on the front of the controller are illuminated, regardless of what is currently being displayed, until the button is released. The displays revert to their original form when the lamp test is complete.

Display of present firmware status

The present firmware status of the SIPART DR19 controller can be displayed if required.

Description

- Pt100 - input RTD

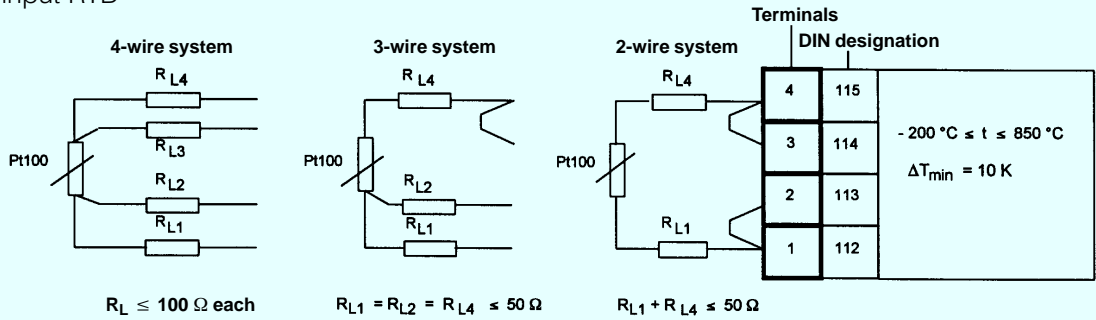

- Thermocouple T and mV source

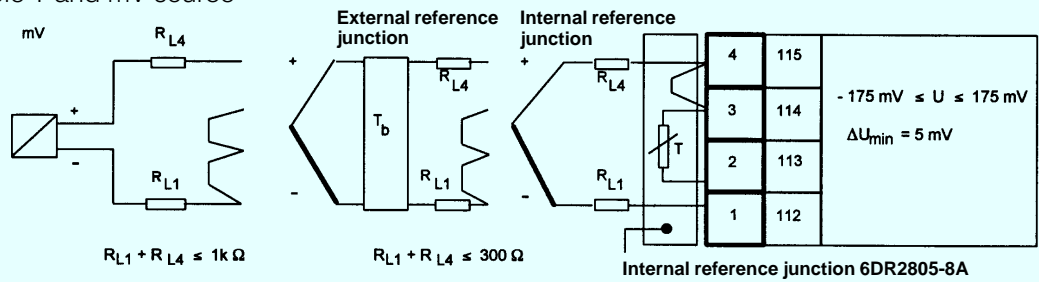

- Resistance input R

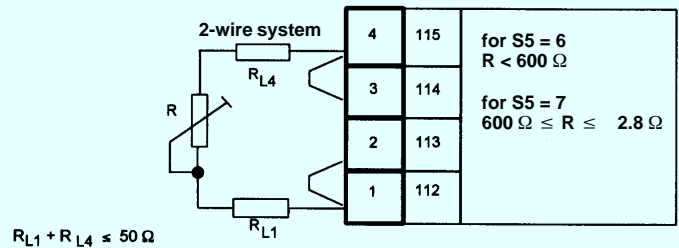

- U or I input
(with measuring range connector)

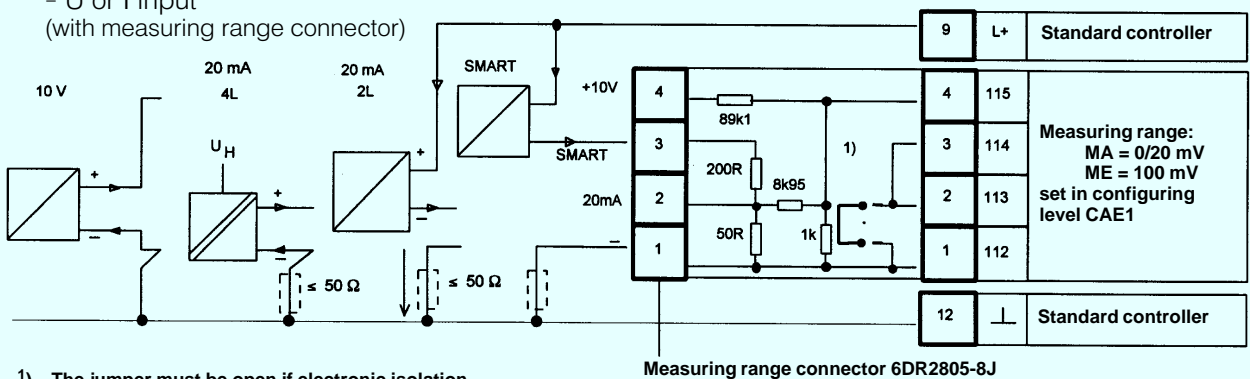

1) The jumper must be open if electronic isolation is being utilized by other loads. When closed, it replaces the connection 1-12.

Fig. 3/12 Wiring of analog input AE1

Description

Configuring switch list

Configuring switch	Function
S1	Type of controller
0	Fixed setpoint / three-component controller, both with 1 or 2 independent setpoints
1	Fixed setpoint / three-component controller, both with 5 independent setpoints
2	Slave / synchronization/ SPC controller
3	DDC controller
4	Ratio controller
5	Program controller
6	Fixed setpoint controller for coupling to a process control system, from firmware release A7 onwards
7	Slave controller for coupling to a process control system, from firmware release A7 onwards
S2	Output configuration
0	K controller
1	Two-step controller for heating/cooling
2	S controller with internal feedback
3	S controller with external feedback
S3	Mains frequency suppression
0	50 Hz
1	60 Hz
S4 to S7	Measured variable and type of sensor for analog input AE1
S8	Configuration of slot 2 (AE2)
S9 to S11	Specifying measured variable, type of sensor and engineering unit for slot 1 (AE3) when configured with UNI module
S12 to S14	Extract square root of analog inputs AE1 to AE3
S15 to S20	Assignment of function inputs x1, x2, x3/we, x4, yN, yR, z to analog inputs AE1 to AE3
S21	Assignment of lineariser to AE1 to AE3 or x1
S22	Configuration of slot 3
S23 to S34	Assignment of control signals CB, He, N, Si, P, ts, +yBL, -yBL, BLB, BLS, BLPS, PU to digital inputs BE1 to BE7
S35 to S41	Logic of control signals
S42	Effect of control signal CB, static or dynamic (pulse)
S43 to S46	Setpoint switchover
S47	Direction of action controller
S48	Feedforward control of D element
S49	Adaptation: type of adaptation
S50 to S54	Manual/Automatic output switchover, priority N or H, disable ly, y limiting
S55 and S56	Manipulated variable display: Selection of displayed variable and logic
S57	Assignment of internal controller signals to the analog output
S58	Assignment of the +/-Δy outputs to the digital outputs BA1/BA2 or the relay outputs BA7 and BA8
S59 to S69	Assignment of alarm signals RB, RC, H, Nw, A1, A2, A3, A4, MUF, +Δw, -Δw to digital outputs BA1 to BA6 or the relay outputs BA7 and BA8
S70 to S75	Program controller, time bus status messages
S76 to S82	Logic of alarm signals
S83 and S84	Assignment of limit monitors A1/A2 and A3/A4 to internal process variables
S85 and S86	Function of limit monitors A1/A2 and A3/A4
S87 to S89	Selection of display values or display switchover
S90 and S91	Restart conditions following restoration of power supply
S92 to S99	Serial interface settings: station no., data transmission rate, parity

On-line parameters

tF	Filter time constant for filter x_d/x_w (adaptive)
V _v	Derivative action gain
K _P	Proportional gain
T _n	Reset time
T _v	Derivative action time
AH	Response threshold
Y ₀	Working point - P(D) controller
SH1 to SH4	Internal setpoints (fixed setpoint controller with 5 setpoints)
Y _A	Lower limit of manipulated variable
Y _E	Upper limit of manipulated variable
t _P	Increase y time / duration of heating period
t _M	Decrease y time / duration of cooling period
t _A	Min. positional pulse interval
t _E	Min. positional pulse length
t ₁ to t ₃	Filter time for the inputs AE1 to AE3
c1 to c7	Constants c1 to c7
dr	Display refresh rate

Off-line parameters

dP	Decimal point (w/x-digital indicator)
dA	Start-of-scale digital indicator
dE	Full-scale digital indicator
A1 to A4	Alarms A1 to A4
HA	Hysteresis A1 to A4
SA	Lower setpoint limit
SE	Upper setpoint limit
SH	Safety setpoint
tS	Setpoint ramp time
vA	Lower ratio factor
vE	Upper ratio factor
YS	Safety manipulated variable
Y1	Two-step controller: split range left (heating)
Y2	Two-step controller: split range right (cooling)
L1 to L11	Output vertices for lineariser (input vertices are equidistant)

SIPART DR19 Controllers

Technical data

Technical data	
<ul style="list-style-type: none"> General 	
Mounting position	Any
Climatic classes	
Storage: 1K2 according to DIN IEC 721 Part 3-1	-25 to +75 °C
Transport: 2K2 according to DIN IEC 721 Part 3-2	-25 to +75 °C
Operation: 3K3 according to DIN IEC 721 Part 3-3	0 to +50 °C
Protection according to EN 60 529	
Front	IP 64
Housing	IP 30
Terminals	IP 20
Controller design	
<ul style="list-style-type: none"> - To DIN EN 61 010 Part 1 (IEC 1010 -1+A1) - Protection class I according to IEC 536 - Outputs are functional extra-low voltages, safely isolated to DIN/VDE 0100 Part 410 Nov. 1983 - Power supply isolated from field signals according to DIN/VDE 106 (DIN/VDE 0551, T1) - Clearances and creepage paths for surge class III and pollution level 2 according to DIN/VDE 0110 Part 1 Jan. 1989, unless stated otherwise 	
The SIPART DR19 controller has already acquired the following certifications:	
<ul style="list-style-type: none"> CE mark 	
The controller conforms with the following harmonized standards:	
EU Certificate of Conformance no. DR19-1/1995 with respect to EMC Guidelines 89/336 EWG	
- Emitted interference	DIN EN 50 081-1 Issued: 3/93, TÜV certified
- Immunity of interference	DIN EN 50 082-2 Issued: 1/93, TÜV certified
- NAMUR, NE 21	Issued: May 1995, TÜV certified
NS Guidelines 73/23 EWG	
- EN 61 010 Part 1	Issued: 09.03.1993
- EN 60 529	Issued: 25.06.1991
<ul style="list-style-type: none"> Certification of Germanischer Lloyd DIN test and inspection mark as temperature controller, test basis DIN 3440 TÜV certificate on approval of a component symbol for water level controller, test requirement according to VdTÜV water level 100 and water level 100/1 	
Weight of standard controller	Approx. 1.2 kg
Color	
Fascia frame	RAL 7037
Fascia	RAL 7035
Material	
Housing and fascia frame	Polycarbonate, reinforced with glass fiber
Front foil	Polyester
Rear panels, modules	Polybutylene-terephthalate
Auxiliary supply connections	
115/230 V AC	3-pin earthed plug IEC 320/V DIN 49457A
24 V AC/DC	Special 2-pin plug
Connections for process signals	
	Multi-pin screw-type terminal blocks, protected against reversed polarity for cables of 1.5 mm ² (AWG 14)
Protective earth connection	
	Earthing screw
Mounting rail on rear of power supply unit (included with the coupling relay module)	NS 35/7.5 DIN/EN 50 022

A rail can be mounted on the rear panel of the power supply. The rail is included in the delivery of the coupling relay mode.

The connector for the auxiliary supply and the screw-type terminal blocks for the process signals are part of the scope of the supply of the standard controller or the option modules. The only exception is the connector for the 6DR2803-8A interface module.

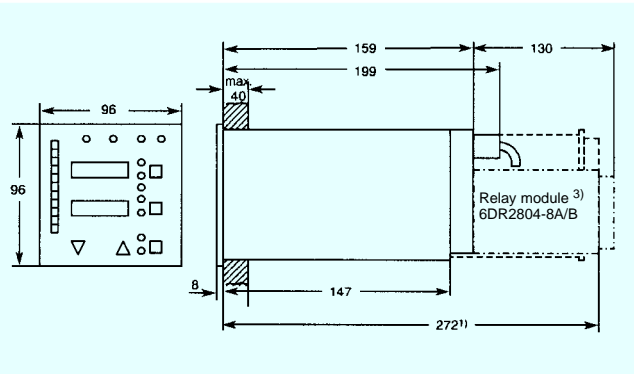
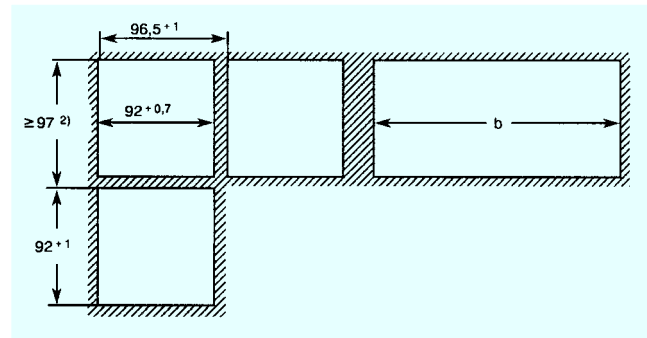

Fig. 3/13 SIPART DR19 controller, dimensions in mm



No. of devices	Cut-out width
2	188 + 1
3	284 + 1
4	380 + 1
.	.
10	956 + 1

Fig. 3/14 Panel cut-outs, dimensions in mm

1) Space required to change motherboard and module.

2) Observe ambient temperature when stacking with no intermediate spacing.

3) A relay module with 2 or 4 relays (6DR2804-8A/-8B) can be snapped onto the rear of the controller. This will increase the mounting depth by 130 mm.

Technical data

Technical data (continued)				
Power supply				
Rated voltage	Switchable 230 V AC 115 V AC		24 V AC/DC	
Operating voltage range	195 to 264 V AC	97 to 132 V AC	20 to 28 V AC	20 to 35 V DC 1)
Frequency range	48 to 63 Hz			-
Peak voltages to IEC 801-5 Pulse: 1.2/50 μ s				
symmetric	1 kV	1 kV	0.5 kV	0.5 kV
asymmetric	2 kV	2 kV	1 kV	1 kV
Total of all output currents (L+, BA, AA and SES)	max. 200 mA			
Power consumption Active power/ Apparent power (capacitive) Standard controller				
- No options, without I_{ext}	5 W/9 VA	5 W/9 VA	4 W/6 VA	4 W
- With options, without I_{ext}	11 W/15 VA	11 W/15 VA	8.5 W/12 VA	8.5 W
- With options, with I_{ext}	15 W/19 VA	15 W/19 VA	12 W/17 VA	12 W
Permitted voltage dips at $0.85 U_N$ Standard controller with options	≤ 20 ms			
Test voltages (1 min)				
- Primary-secondary	1.5 kV AC		500 V AC	
- Primary-protective conductor	1.5 kV AC		500 V AC	
- Secondary protective conductor	700 V DC		700 V DC	
Program controller/transmitter				
Program	P1 P2 P1 and P2 connected			
Intervals per program	P1 = 10 P2 = 5			
Variable ramp/stop time	All intervals can be used as ramps or stop time, interval and amplitude for interval end can be modified			
Interval period on time basis	00 . 00 to 23 . 59 00 . 00 to 59 . 59			
- Hrs / Mins				
- Mins / Secs				
Time base	Same for all intervals			
Status signals	6 digital outputs (time-controlled) Each interval can be signalled on each digital output			
Program - Start - Stop	From front panel or digital input			
Reset	From front panel or digital input			

Standard controller	
Analog input AE1	See standard controller, analog input AE1
Transmitter supply L+ Rated voltage On-load current Short-circuit current	20 to 26 V ≤ 60 mA, short-circuit proof ≤ 200 mA, pulsed
Digital inputs BE1 and BE2 Signal status "0" Signal status "1" Input impedance	≤ 4.5 V or open ≥ 13 V ≥ 27 k Ω
Digital outputs BA1 and BA2 (with wired OR diodes) Signal status "0" Signal status "1" On-load current Short-circuit current	≤ 1.5 V +19 to 26 V ≤ 50 mA ≤ 80 mA, pulsed
Analog output Iy (K controller) Rated signal range Output range Load voltage Max. permitted inductive load	0 to 20 mA or 4 to 20 mA 0 to 20.5 mA or 3.8 to 20.5 mA -1 to +18 V 0.1 H
Relay output (S controller) Contact material Contact rating Max. switching voltage Max. switching current Max. switching capacity Service life Mechanical Electrical 230 V AC, Ω loading Spark suppressor	Ag-Ni 250 V AC 250 V DC 8 A 8 A 1250 VA 100 W at 24 V 30 W at 250 V $2 \cdot 10^7$ switching operations $2 \cdot 10^6$ switching operations 22 nF and 220 Ω connected in series with a 420 V varistor wired in parallel
CPU data Cycle time	100 ms
A/D conversion Method Resolution Zero error Gain error Linearity deviation	Successive approximation with > 120 measurements per input and averaging within 20 or 16.67 ms 18 bit for AE1 11 bit for further AE and AA ≤ 0.2 % of measuring span ≤ 0.2 % of measuring span ≤ 0.2 % of measuring span
Display technology Digital x indicator Digital w indicator Character height Display range Numerical range Decimal point Refresh rate Analog indicator Display range - for x_d/x_w - internal process quantities	4-digit, red, 7-segment LED display 4-digit, green, 7-segment LED display 10 mm Adjustable start and full scale -1999 to +9999 Adjustable (fixed-point) 0.1 to 9.9 s, variable Vertical row of 21 LEDs (red) ± 5 % to ± 20 % 0 to 100 %

1) Includes harmonic content.

Technical data

Technical data (continued)																							
Standard controller, analog input AE1																							
Pt 100 resistance thermometer																							
Line resistance - 2-wire circuit	Lead resistance $R_{Ab} = R_{L1} + R_{L4}$ defined by parameters or automatic compensation via configuration $R_{L1} + R_{L4} \leq 50 \Omega$																						
- 3-wire circuit	No compensation necessary if $R_{L1} = R_{L2} = R_{L4} \leq 50 \Omega$																						
- 4-wire circuit	No compensation necessary R_L each $\leq 100 \Omega$																						
Measuring current	400 μ A																						
Configurable measuring range																							
Start	$R_{tA} \geq 18.49 \Omega$, $t_A \geq -200 \text{ }^\circ\text{C}$																						
End	$R_{tE} \leq 390.26 \Omega$, $t_E \leq 850 \text{ }^\circ\text{C}$																						
Recommended min. span	10 K																						
Characteristic	Temperature linear																						
Filter time constant	≈ 10 ms																						
Input	Non-floating																						
Thermocouples																							
Thermocouples, configurable to DIN IEC 584, part 1	<table border="0"> <tr> <td>Cu-CuNi</td> <td>Type</td> </tr> <tr> <td>Fe-CuNi</td> <td>T</td> </tr> <tr> <td>NiCr-Ni</td> <td>J</td> </tr> <tr> <td>NiCr-CuNi</td> <td>K</td> </tr> <tr> <td>Pt10Rh-Pt</td> <td>E</td> </tr> <tr> <td>Pt13Rh-Pt</td> <td>S</td> </tr> <tr> <td>Pt30Rh-Pt6Rh</td> <td>R</td> </tr> <tr> <td>NiCrSi-NiSi</td> <td>B</td> </tr> <tr> <td></td> <td>N</td> </tr> <tr> <td></td> <td>U</td> </tr> <tr> <td></td> <td>L</td> </tr> </table>	Cu-CuNi	Type	Fe-CuNi	T	NiCr-Ni	J	NiCr-CuNi	K	Pt10Rh-Pt	E	Pt13Rh-Pt	S	Pt30Rh-Pt6Rh	R	NiCrSi-NiSi	B		N		U		L
Cu-CuNi	Type																						
Fe-CuNi	T																						
NiCr-Ni	J																						
NiCr-CuNi	K																						
Pt10Rh-Pt	E																						
Pt13Rh-Pt	S																						
Pt30Rh-Pt6Rh	R																						
NiCrSi-NiSi	B																						
	N																						
	U																						
	L																						
to DIN 43 710																							
Compensating reference junction																							
Internal	Reference junction terminal required																						
External	Temperature of external reference junction entered as parameter																						
Line resistance	$\leq 300 \Omega$																						
Configurable measuring range																							
Start	≥ -175 mV																						
End	$\leq +175$ mV																						
Recommended min. span	5 mV																						
Configurable characteristic	Linear with voltage or temperature																						
Filter time constant	≈ 10 ms																						
Input current	$\leq 1 \mu$ A																						
Permitted common mode voltage	≤ 1 V																						
Stat. destruction limit across inputs	± 35 V																						

mV source	
Configurable measuring range	
Start	≥ -175 mV
End	$\leq +175$ mV
Recommended min. span	5 mV
Line resistance	≤ 1 k Ω
Characteristic	Voltage linear
Input current	$\leq 1 \mu$ A
Permitted common mode voltage	≤ 1 V
Stat. destruction limit across inputs	± 35 V
Resistance based sensor R	
Configurable measuring range	Measuring range
	Measuring range limits incl. line resistance
Recommended min. span	$R_{tot} \leq 600 \Omega$ $600 \Omega \leq 2.8$ k Ω
Input current	30 Ω 70 Ω 400 μ A 140 μ A
Linearity error	± 60 m Ω ± 0.2 Ω
Test voltage	500 V AC
Input	Non-floating
mA source with additional measuring range connector 6DR2805-8J (with impedance already included in Smart instruments)	
Measuring range	
Start	0/4 mA Δ 0/20 mV
End	20 mA Δ 100 mV
Transformation error	0.3 %
Input resistance	50 Ω
Smart input resistance	250 Ω
Permitted common mode voltage	≤ 1 V
Stat. destruction limit across inputs	± 40 mA
10 V voltage source with additional measuring range connector 6DR2805-8J	
Measuring range, can be compensated	
Start	0/2 V Δ 0/20 mV
End	10 V Δ 100 mV
Transformation error	0.2 %
Input resistance	90 k Ω
Permitted common mode voltage	≤ 1 V
Stat. destruction limit across inputs	± 35 V

